

## STAINLESS STEEL CENTRIFUGAL PUMPS

### FCTSS SERIES

---



## SPECIFICATIONS

Power Range	: Upto - 3,0kW
Speed	: 2900 rpm
Degree of Protection	: IP 54 / IP 55
Class of Insulation	: 'B' / 'F'
Versions	: Single phase - 230V, 50Hz, A.C. Supply (Permanent split capacitor-PSC) Three phase - 380-415V, 50Hz A.C. supply
Direction of Rotation	: Clockwise viewed from driving end
Type of Duty	: S1 (Continuous)
Nominal Suction Size in mm	: Upto 50
Nominal Delivery Size in mm	: Upto 50

## MATERIALS OF CONSTRUCTION

Pump Casing	: S.S 304
Motor Frame	: Aluminium
Impeller	: S.S 304
Shaft	: S.S 304 / Carbon Steel
Sealing	: Mechanical Seal (Carbon & Ceramic)

## PUMP OPERATING LIMITS

Maximum Head	: 35,5 m
Maximum Suction Lift	: upto 7m
Maximum Liquid Temperature	: 40°C
Maximum Ambient Temperature	: 50°C

## FEATURES

- High Operating efficiency resulting in lower power consumption.
- Dynamically balanced rotating parts.
- Inbuilt thermal overload protector in all single phase pumps.
- Complete SS construction more suitable for potable water.

## APPLICATIONS

Residential, Irrigation, Small Farms, Pressure Boosting Units, Utility supply in Industrial, Food Processing Industries, Washing Systems.

## PERFORMANCE CHART

### FCTSS SERIES

PUMP MODEL		MOTOR POWER		RATED CURRENT(A)		NOMINAL PUMP SIZE in Inches (Suc x Del)	DISCHARGE IN lps / m <sup>3</sup> /h										
							0	0,27	0,55	0,83	1,1	1,3	1,6	1,9	2,2	2,5	2,9
230V	380V	kW	HP	1Ph 230V	3Ph 380V		0	1	2	3	4	5	6	7	8	9	10
							TOTAL HEAD IN METRES										
FCTSS-5/03M	FCTSS-5/03T	0,37	0,5	2,4	-	1¼ x 1	16	15,5	15	14,5	13	11,5	10,5	9			
FCTSS-6/05M	FCTSS-6/05T	0,55	0,75	3,8	1,4	1¼ x 1	19,5	18	17	15,5	13,5	12,5	11	8			
FCTSS-8/07M	FCTSS-8/07T	0,75	1,0	5,2	1,8	1¼ x 1	23	22	21,5	20,5	19,5	18	17	16	14,5	13	
FCTSS-7/10M	FCTSS-7/10T	1,0	1,3	6,2	2,4	1¼ x 1	29	28	26,5	25,5	24	22,5	20,5	18,5	15,5	11,5	
FCTSS-8/11M	FCTSS-8/11T	1,1	1,5	7	2,6	1¼ x 1	26,5	26	25,5	25	24,5	23,5	22	20,5	19,5	18	17

## PERFORMANCE CURVES

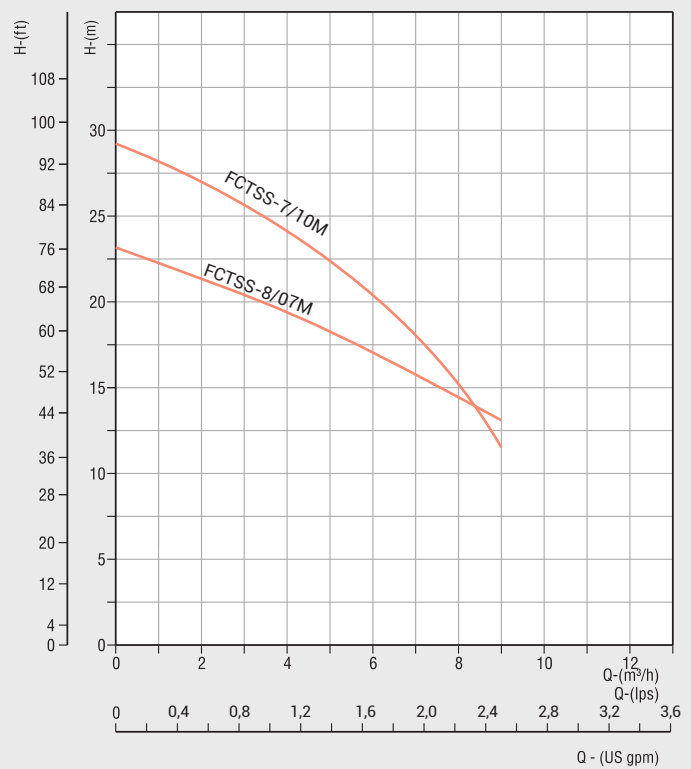
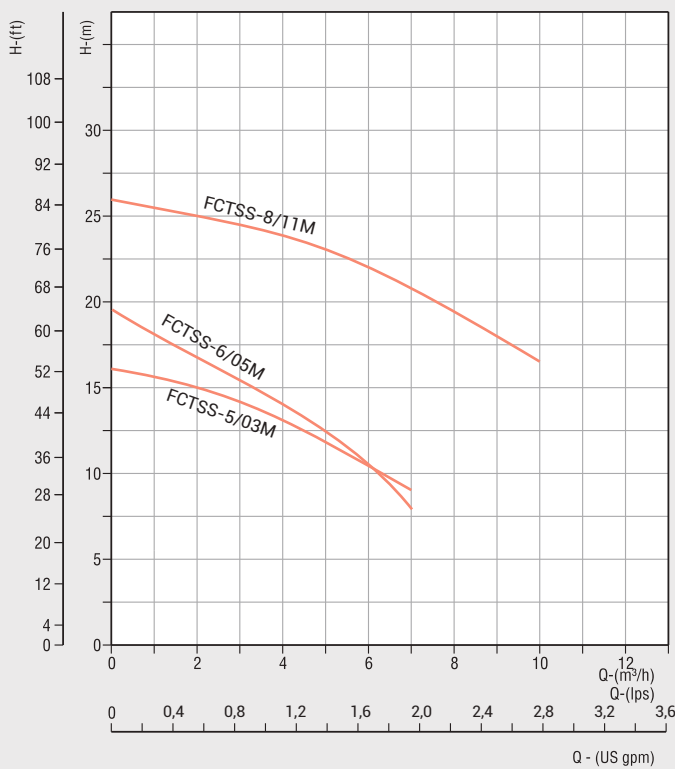

## PERFORMANCE CHART FCTSS SERIES

PUMP MODEL		MOTOR POWER		RATED CURRENT(A)		NOMINAL PUMP SIZE in Inches (Suc x Del)	DISCHARGE IN lps / m <sup>3</sup> /h											
							0	0,27	0,55	0,83	1,1	1,3	1,6	1,9	2,2	2,5	2,9	3,3
230V	380V	kW	HP	1Ph 230V	3Ph 380V		0	1	2	3	4	5	6	7	8	9	10	12
							TOTAL HEAD IN METRES											
FCTSS-8/15M	FCTSS-8/15T	1,5	2,0	9,2	3,5	1¼ x 1	31	30	29	28,5	27,5	27	26	25	24,5	23	22	20,5
FCTSS-8/18M	FCTSS-8/18T	1,8	2,5	13	4,1	1¼ x 1	36,5	35	34	33	32	30	28,5	27	24	20,5	16,5	
FCTSS-10/18M	FCTSS-10/18T	1,8	2,5	13	4,1	1¼ x 1	30	29,5	29	28,5	28	27,5	27	26	25	24	23	21

## PERFORMANCE CURVES

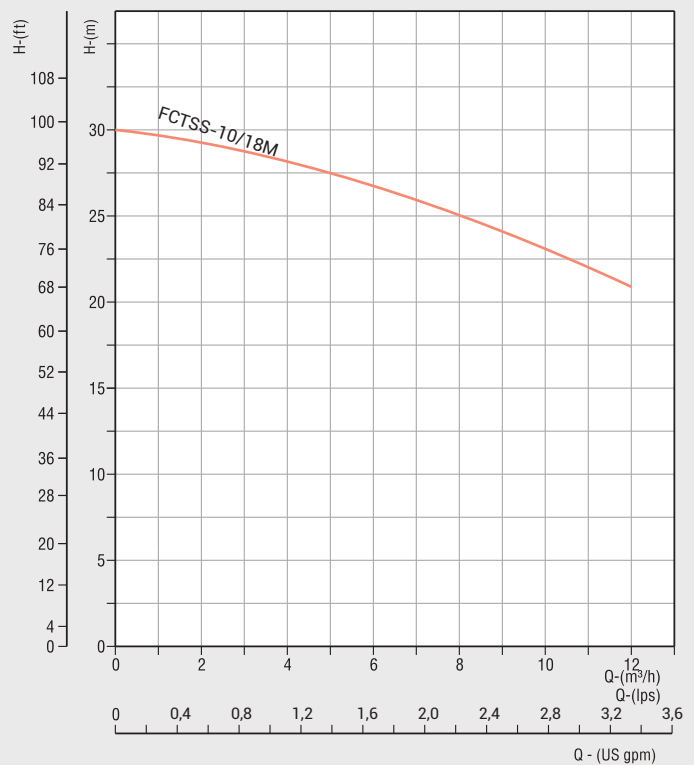
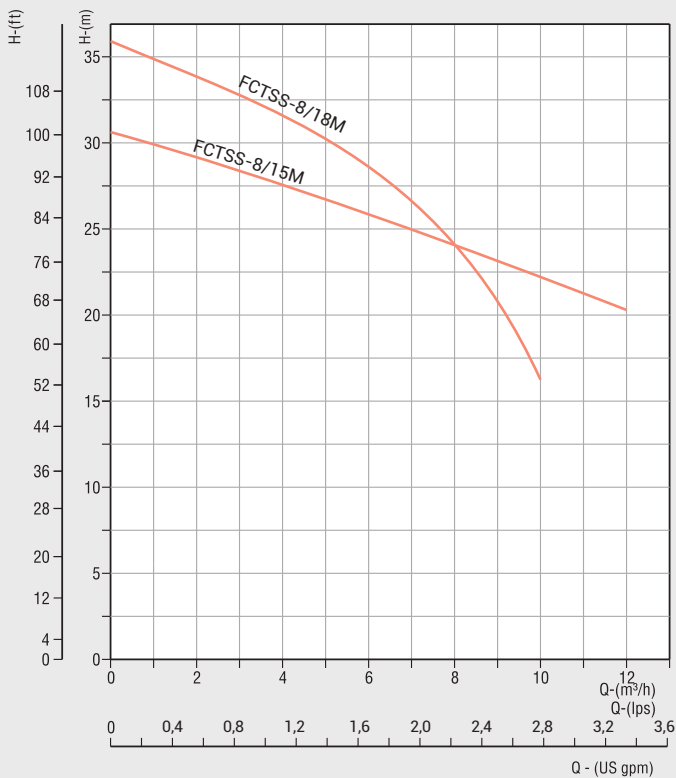

## PERFORMANCE CHART

### FCTSS SERIES

PUMP MODEL		MOTOR POWER		RATED CURRENT (A)		NOMINAL PUMP SIZE in Inches (Suc x Del)	DISCHARGE IN lps / m <sup>3</sup> /h												
							0	0.8	1.7	2.5	3.3	4.2	5.0	5.8	6.7	7.5	8.3	9.2	10
230V	380V	kW	HP	1Ph 230V	3Ph 380V		TOTAL HEAD IN METRES												
							0	3	6	9	12	15	18	21	24	27	30	33	36
FCTSS-16/11M	FCTSS-16/11T	1,1	1,5	7	2,6	2 x 2	21	20	19	18,5	17,5	16,5	14,5	13	11	8,5	7 (29m <sup>3</sup> /h)		
FCTSS-18/15M	FCTSS-18/15T	1,5	2,0	9,2	3,5	2 x 2	25,5	25	23,5	22,5	21	19	17,5	16	13,5	11	8,5	8 (31m <sup>3</sup> /h)	
FCTSS-24/22M	FCTSS-24/22T	2,2	3,0	14	4,9	2 x 2	26	25,5	25	24,5	23,5	22,5	21,5	20	18,5	17	15	13	12 (34m <sup>3</sup> /h)
-	FCTSS-25/30T	3,0	4,0	-	6,3	2 x 2	29	28,5	28	27,5	26,5	25,5	24,5	23	22	20	17,5	15,5	13,5 (35m <sup>3</sup> /h)

## PERFORMANCE CURVES

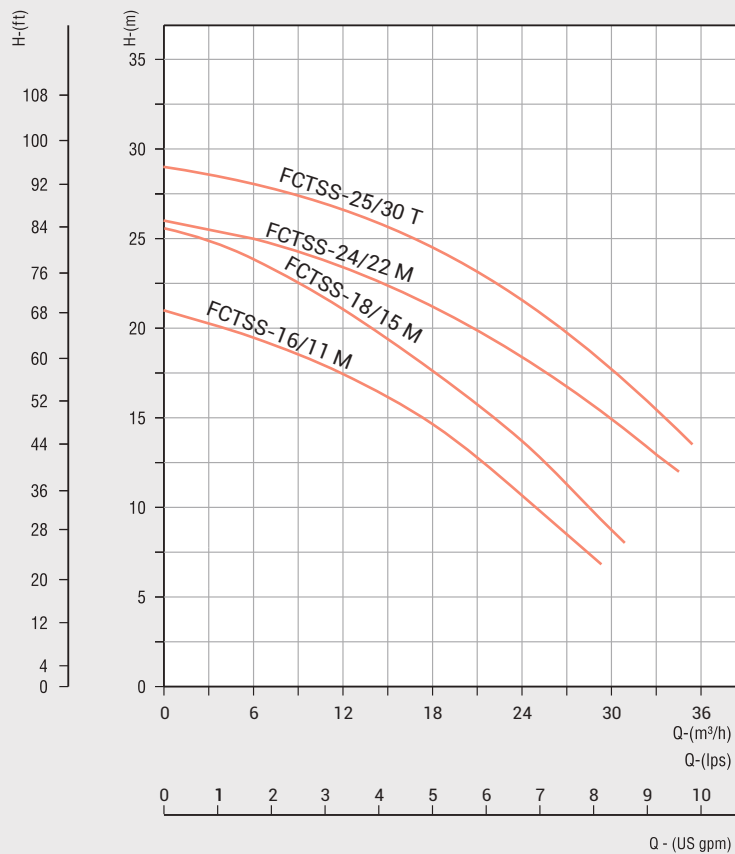

## DIMENSIONAL DATA

### FCTSS SERIES

PUMP MODEL		MOTOR POWER		A	B	C	H	H1	H2	L	L1	APPROX. NETT WT in kg
230V	380V	kW	HP									
FCTSS-5/03M	FCTSS-5/03T	0,37	0,5	170	100	50	180	84	186	270	120	6,5
FCTSS-6/05M	FCTSS-6/05T	0,55	0,75	213	140	47	222	110	242	313	138	12,5
FCTSS-8/07M	FCTSS-8/07T	0,75	1,0	213	140	47	222	110	242	313	138	13,5
FCTSS-7/10M	FCTSS-7/10T	1,0	1,3	213	140	47	222	110	242	313	138	15,5
FCTSS-8/11M	FCTSS-8/11T	1,1	1,5	213	140	47	222	110	242	313	138	15,5
FCTSS-8/15M	FCTSS-8/15T	1,5	2,0	234	150	49	240	120	251	337	140	18,5
FCTSS-8/18M	FCTSS-8/18T	1,8	2,5	234	150	49	240	120	251	337	140	22,0
FCTSS-10/18M	FCTSS-10/18T	1,8	2,5	231	140	47	222	110	255	366	138	21,5

\* All Dimensions are in mm.

## DIMENSIONAL DRAWINGS

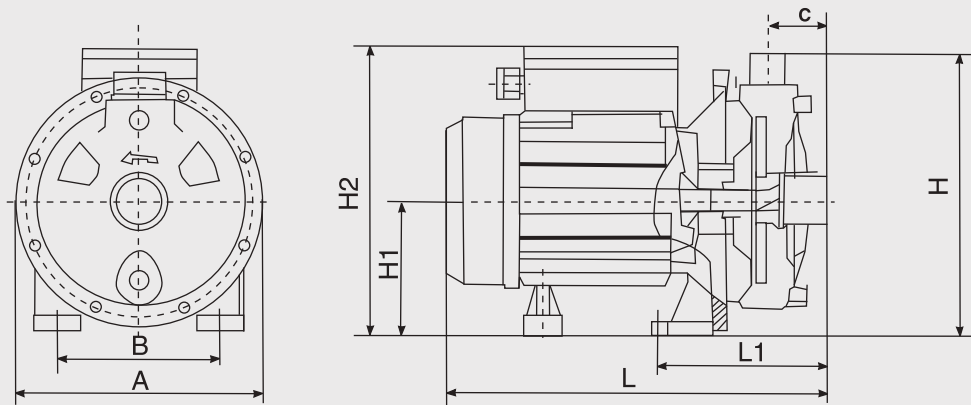

## DIMENSIONAL DATA

### FCTSS SERIES

PUMP MODEL		MOTOR POWER		A	B	C	H	H1	H2		L	L1	APPROX. NETT WT in kg
230V	380V	kW	HP						1Ph	3Ph			
FCTSS-16/11M	FCTSS-16/11T	1,1	1,5	193	108	82	258	125	265	235	378	165	16,5
FCTSS-18/15M	FCTSS-18/15T	1,5	2,0	193	108	82	258	125	265	235	378	165	18
FCTSS-24/22M	FCTSS-24/22T	2,2	3,0	193	108	82	258	125	242	242	415	165	22
-	FCTSS-25/30T	3,0	4,0	193	108	82	258	125	-	242	432	165	23

\* All Dimensions are in mm.

## DIMENSIONAL DRAWINGS

